

3100 } *installation guide*

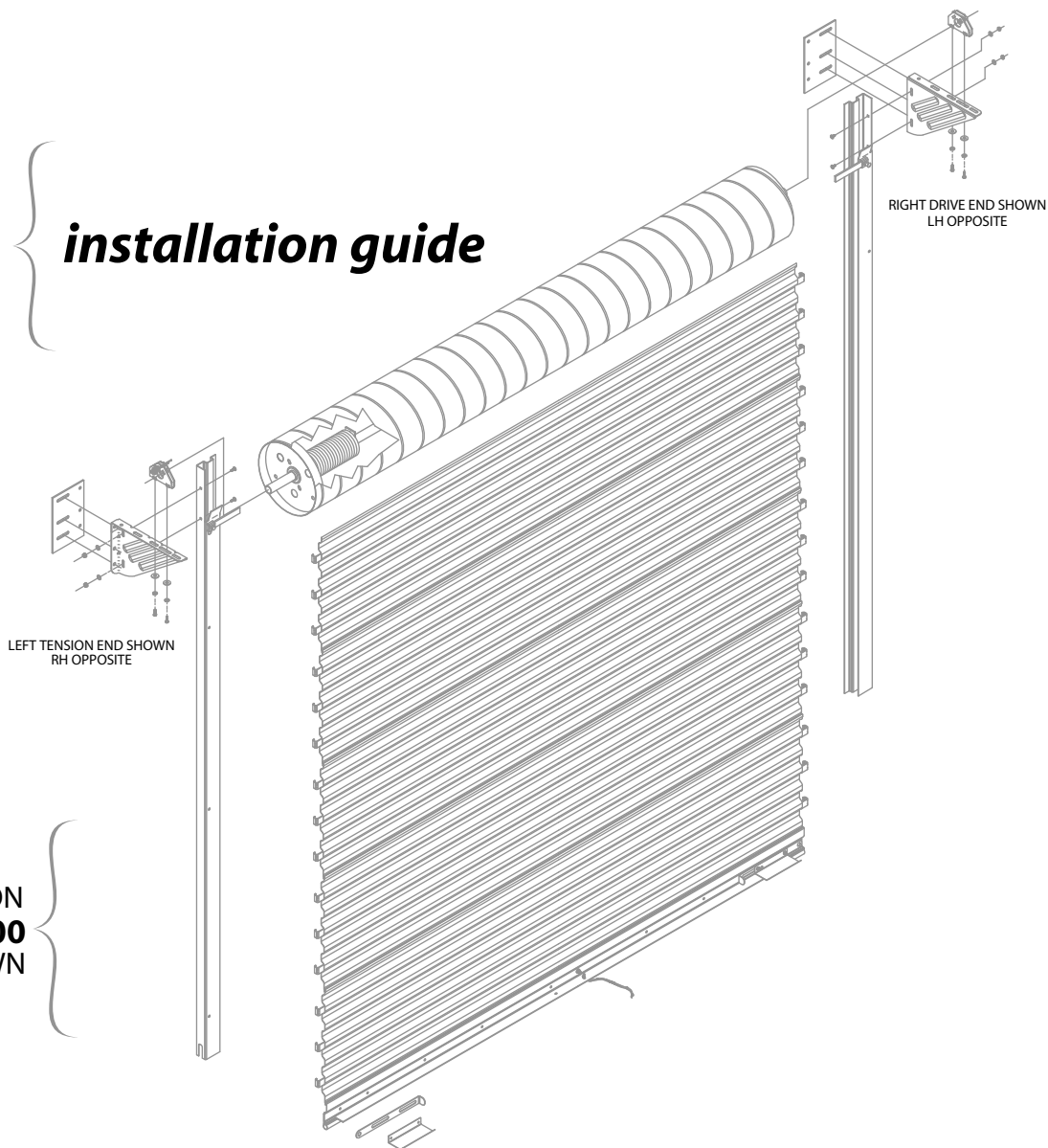

PUSH-UP OPERATION
3100
 SHOWN

⚠ WARNING!
 A rolling door is a large heavy object that moves with the help of springs under extreme tension and electric motors. Moving objects, springs under tension and electric motors can cause serious injuries or death. For your safety and the safety of others, follow these instructions.

⚠ CAUTION
 Use proper lifting equipment and correct lifting procedures to avoid damage or injury.

POTENTIAL HAZARD	EFFECT	PREVENTION
 MOVING DOOR	CAN CAUSE SERIOUS INJURY OR DEATH	<p>DO NOT stand or walk under moving door. Keep door in full view and free of obstructions while operating.</p> <p>DO NOT allow children to operate the door or door controls.</p>
 EXTREME SPRING TENSION	CAN CAUSE SERIOUS INJURY OR DEATH	<p>Installation, repairs and adjustments must be made by a trained rolling service door systems technician using proper tools and instructions.</p> <p>DOOR MUST BE FULLY OPENED WHEN MAKING ADJUSTMENTS.</p>
 ELECTRIC SHOCK	CAN CAUSE SERIOUS BURNS OR DEATH	Turn off electrical power before removing operator cover. Operator must be electrically grounded.

IMPORTANT NOTE:
 Do not cut tape and plastic wrap that holds the door in a roll until you are directed to do so in step 14B.
 Janus International Corporation cannot guarantee or accept responsibility for doors that are not installed as directed. Please read and understand all instructions before beginning the installation process.

SIDE ROOM REQUIREMENTS

* All dimensions are taken from edge of opening

	OPERATION	BACK OF GUIDE	OUTSIDE OF BRACKET TENSIONER END	OUTSIDE OF BRACKET DRIVE END (NON-TENSIONER)	OUTSIDE OF HAND CHAIN DRIVE	EACH END OF AXLE
3100 DOOR SERIES	Push-up	4-1/4"	5-7/8"	5-7/8"	—	8-3/4"
	Reduced Hand Chain	4-1/4"	5-7/8"	6-5/8"	8-1/8"	8-3/4"
	Electric	4-1/4"	5-7/8"	7-3/8"	—	8-3/4"

CLEARANCE CHARTS FIGURE 1

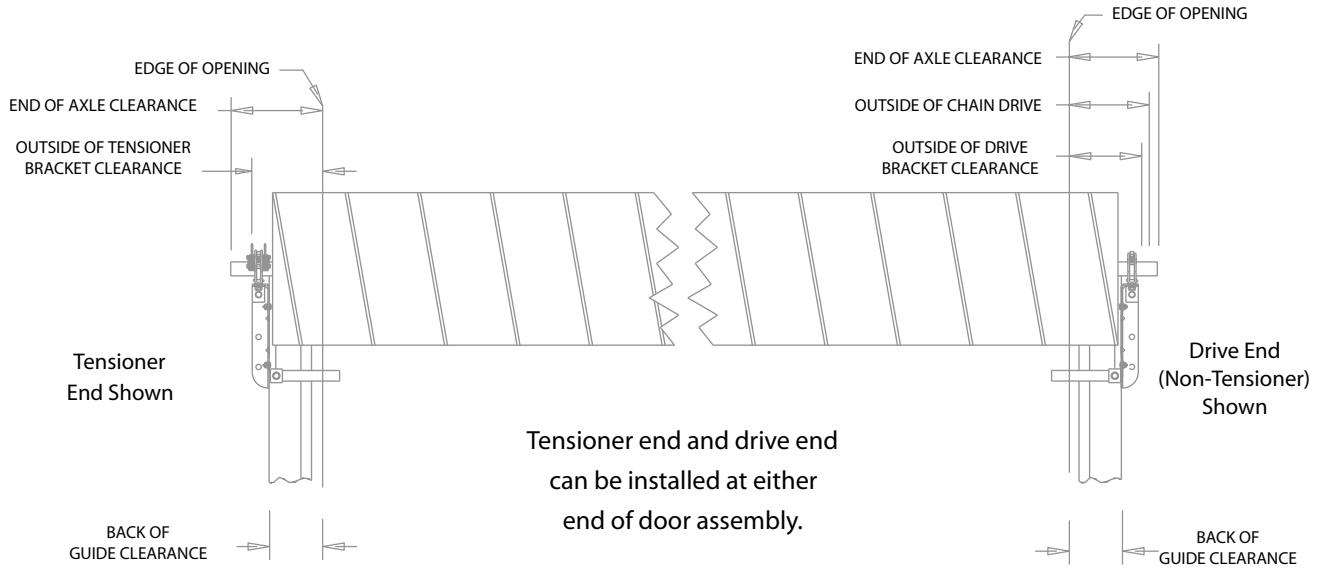

HEADROOM REQUIREMENTS

OPENING HEIGHT	VERTICAL HEADROOM	HORIZONTAL HEADROOM
THRU 8'-0"	17"	19"
OVER 8'-0" THRU 10'-0"	19"	21"
OVER 10'-0" THRU 14'-0"	20"	22"
OVER 14'-0" THRU 16'-0"	21"	23"
OVER 16'-0" THRU 18'-0"	22"	24"
OVER 18'-0" THRU 20'-0"	23"	25"

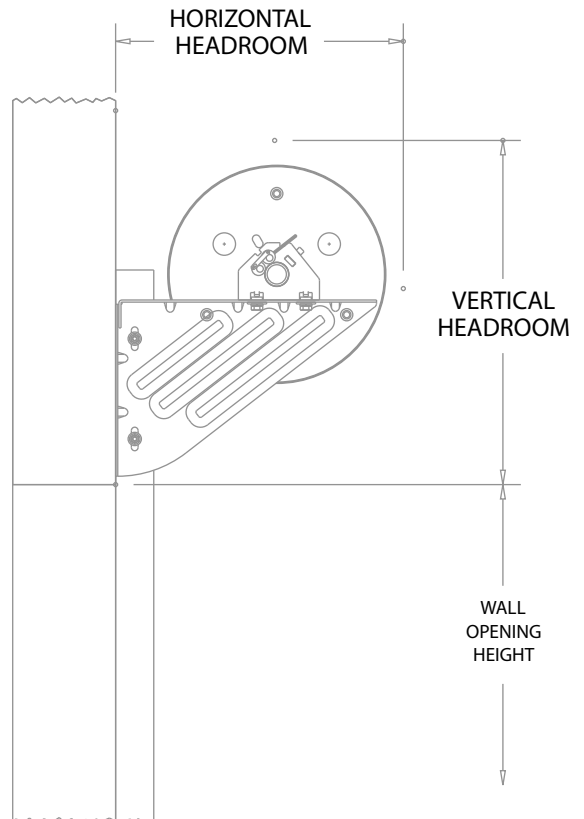

STEP 1: WALL OPENING

- A. Check wall opening width and height and verify these measurements against size of door to be installed.
- B. Verify that jambs are plumb.
- C. Check floor and header for level.
- D. Check for adequate side clearance at jambs and clearance above and at sides of header. Check vertical and horizontal requirements. See Clearance charts **figure 1** for minimum requirements.
- E. Verify that the guide mounting surface on the jamb is flush.
- F. Make sure all parts required for installation are with the door.

STEP 2: MOUNTING PLATES (OPTIONAL EXCEPT FOR STEEL JAMBS)

- A. If door will install to steel jambs, mounting plates for the door brackets are required and may be welded or bolted to the jambs.
- B. Top of mounting plates should be located 10" above top of opening and be level with each other. Side of mounting plates should be even with edge of opening. If opening width is off, adjust locations accordingly. **See figure 2.**
- C. If mounting plates are bolted to jambs, do not use a flat washer between bolt and mounting plate. **See figure 3.**

NOTE: DOOR DRIVE OPERATION MAY BE INSTALLED ON EITHER END OF DOOR ASSEMBLY.

STEP 3: BRACKETS TO GUIDES

- A. Attach door brackets to guides, locating top surface of bracket 2" below top of guide. Use 2 each 1/4-20 x 5/8" carriage bolts, 1/4-20 serrated flange hex nuts and 1/4" flat washers per bracket for tensioner end and the non-tensioner (drive) end for push-up operation. **See figures 5 and 6.**
- B. For reduced hand chain drive end, install drive bracket with 2 each 1/4-20 x 1-3/4" carriage bolts, 1/4-20 serrated flange hex nuts and 1/4" flat washers. Insert 1 each 1-1/4" O.D. x 3/4" long spacer tube between guide and bracket at each bolt location. **See figure 7.**
- C. For electric operation drive end, install drive bracket with 2 each 1/4-20 x 2-1/2" carriage bolts, 1/4-20 serrated flange hex nuts and 1/4" flat washers. Insert 2 each 1-1/4" O.D. x 3/4" long spacer tubes between guide and bracket at each bolt location. **See figure 8.**

STEP 4: GUIDES AND BRACKETS TO JAMB

- A. Attach brackets and guides to jambs using fasteners shown in **table 1**.
- B. The guides should be mounted centered about the opening and spaced curtain width + 4" apart for opening widths through 12' or curtain width + 3-3/4" for opening widths over 12' through 16'. This spacing is measured from back of guide to back of guide. **See figure 3.** Both guides must be plumb.
- C. Once both guides have been correctly positioned, attach them to the jambs using the appropriate fastener at each hole location. **See table 1 and figure 3.**
- D. Check top surface of brackets to verify they are level with each other. If they are not, loosen the bracket-to-guide attachment fasteners and slide bracket(s) vertically until level. Tighten bracket-to-guide fasteners.
- E. Install 3 bracket-to-jamb attachment fasteners for each bracket. **See table 1.**

WARNING!

DOOR CAN FALL IF BOTH BRACKETS ARE NOT SECURELY FASTENED TO THE JAMBS. ALL FASTENERS ATTACHING BRACKETS TO JAMBS MUST FIT SECURELY INTO A STRUCTURAL MEMBER OR SURFACE. IF DOOR FALLS, SERIOUS INJURY OR DEATH AND/OR DAMAGE TO DOOR CAN RESULT.

TABLE 1: Wall Fasteners included for jamb attachment of Brackets and Guides.

ITEM	JAMB	FASTENERS	DRILL SIZE
Brackets	Steel	3/8-16 x 1-1/4" Hex Bolt and Nut	7/16"
	Concrete or Filled Block	3/8" x 1-3/4" Powers Wedge-Bolt	Powers 01316
Guides	Steel	1/4" x 14 x 1" TEKS Screw	None
	Concrete or Filled Block	3/8" x 4" Powers Wedge-Bolt	3/8" x 10" O.A.L.

FIGURE 2
MOUNTING PLATE
INSTALLATION

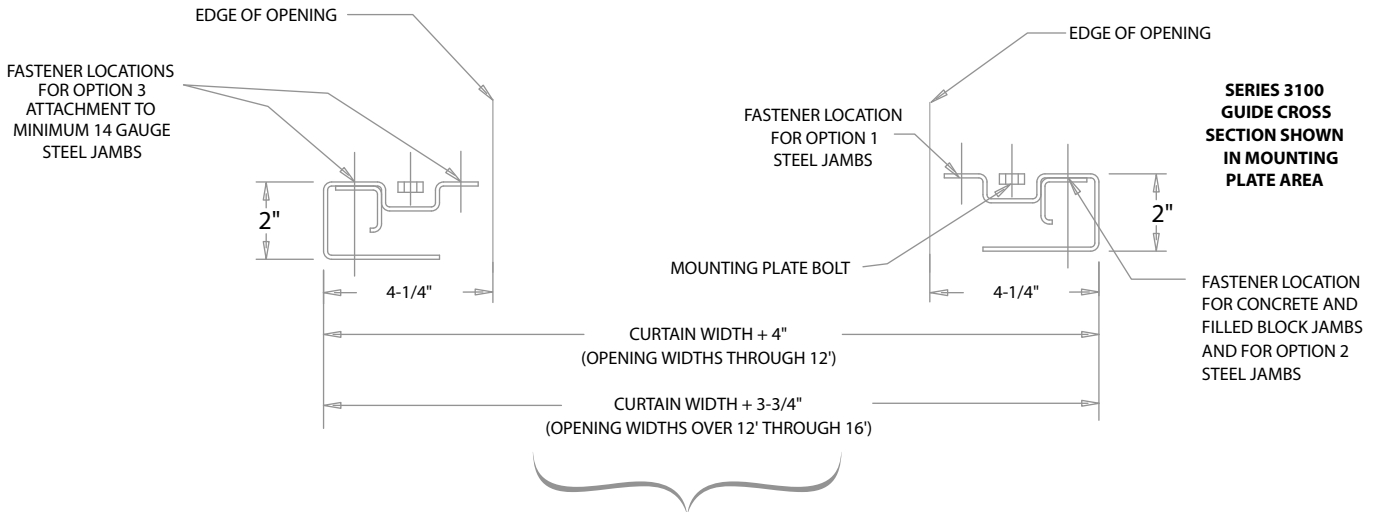
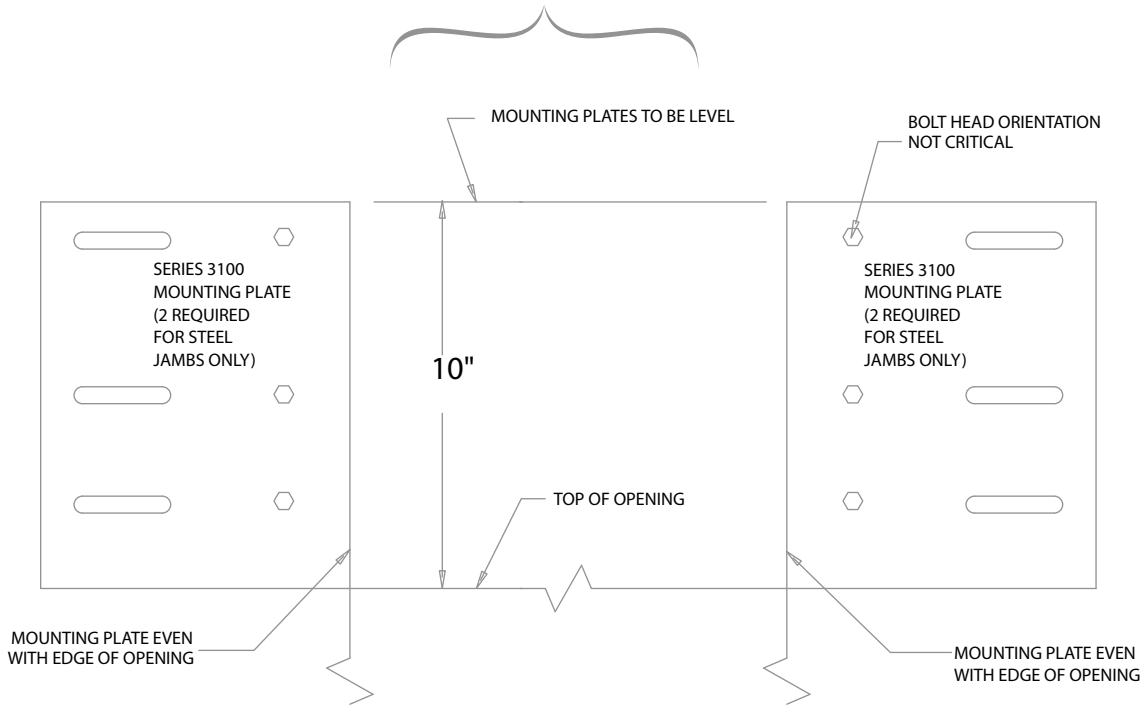
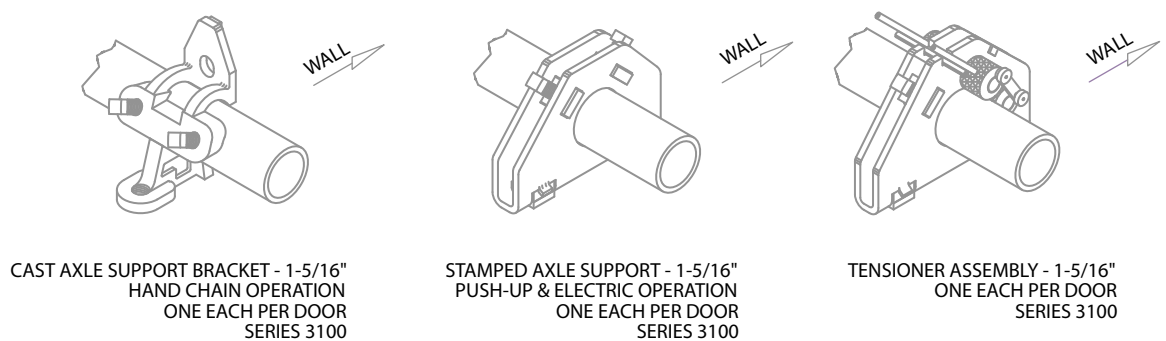

FIGURE 3
GUIDE
INSTALLATION

FIGURE 4
TENSIONER
END



STEP 5: TENSIONER END

- A. Using tensioner assembly's spring roll pin located in knurled wheel, rotate upward in the direction that clears the axle.
- B. Slide tensioner assembly over axle, with arrow pointing toward wall. Release pin. **See figures 4 and 5.**

WARNING!

TENSIONER ASSEMBLY MUST BE ORIENTED ON AXLE WITH THE ARROW POINTING TOWARD THE WALL. IF THIS IS NOT DONE, IT WILL NOT OPERATE AS DESIGNED, WHICH MAY CAUSE SERIOUS INJURY OR DEATH DUE TO THE DOOR SUDDENLY LOSING SPRING TENSION AND RAPIDLY MOVING DOWNWARD.

STEP 6: PUSH-UP NON-TENSIONER END

- A. Slide stamped axle support over axle, with arrow pointing toward wall. **See figures 4 and 6.**

STEP 7: REDUCED CHAIN DRIVE END

- A. Fasten 63 tooth cast ring gear to drum using 3 each 3/8-16 x 1-1/2" grade 5 hex bolts and 3/8" lock washers.
- B. Install 2 each 3/8-16 x 1" square head setscrews in the threaded holes in the cast axle support bracket. These will be tightened against the axle later.
- C. Slide cast axle support bracket over axle. **See figures 4 and 7.**

STEP 8: ELECTRIC DRIVE END

- A. Locate 3 each 1" O.D. x 2-3/8" long spacer tubes and 9" long x 2-5/8" offset struts between 72 tooth #41 sprocket and drum. Attach sprocket with 3 each 3/8-16 x 3-1/2" grade 5 hex bolts and 3/8" lock washers.
- B. Slide stamped axle support over axle, with arrow pointing toward wall. **See figures 4 and 8.**

STEP 9: LIFTING DOOR ASSEMBLY

- A. Orient door with bottom bar located at 12 o'clock position.
- B. Lift door assembly using a forklift that has padded forks in order to prevent damage to curtain.
- C. Position door on brackets with tensioner and axle support resting safely on top of bracket flange.
- D. Door should be positioned as close as possible to the header and still be able to rotate and clear bottom bar.
- E. Each end of door should be equal distance from the header and the curtain must be centered in the opening.

WARNING!

DO NOT ALLOW DOOR ASSEMBLY TO ROLL OFF BRACKETS OR MOVE SIDEWAYS OFF EDGE OF BRACKET. IF DOOR FALLS, SERIOUS INJURY OR DEATH AND/OR DAMAGE TO DOOR CAN RESULT.

STEP 10: TENSIONER END

- A. Attach tensioner assembly to door bracket using 2 each 3/8-16 x 3/4" grade 5 hex bolts, 3/8" lock washers and 3/8" flat washers. **See figures 4 and 5.**

STEP 11: PUSH-UP NON-TENSIONER END

- A. Attach stamped axle support to door bracket using 2 each 3/8-16 x 3/4" grade 5 hex bolts, 3/8" lock washers and 3/8" flat washers. **See figures 4 and 6.**

STEP 12: REDUCED HAND CHAIN DRIVE END

- A. Attach cast axle support bracket to door bracket using 3/8-16 x 3/4" grade 5 hex bolt, 3/8" lock washer and 3/8" flat washer.
- B. Position chain hoist assembly on door bracket next to cast axle support and attach to door bracket using 2 each 3/8-16 x 3/4" grade 5 hex bolts, 3/8" lock washers and 3/8" flat washers. The spur gear on the hoist will engage with the internal teeth of the cast ring gear on the end of the drum. **See figure 7.**
- C. Connect cast axle support bracket to side of chain hoist using 3/8-16 x 3/4" hex bolt and 3/8" lock washer. **See figures 4 and 7.**
- D. Feed hand chain over chain pocket wheel and through hoist. Connect ends of hand chain, being careful not to twist chain. Hand chain may be lengthened or shortened as necessary.
- E. Install hand chain keeper on wall or jamb.

STEP 13: ELECTRIC DRIVE END

- A. Attach stamped axle support to door bracket using 2 each 3/8-16 x 3/4" grade 5 hex bolts, 3/8" lock washers and 3/8" flat washers. **See figures 4 and 8.**

STEP 14: SETTING INITIAL SPRING TENSION

- A. Rotate door 1-1/2 revolutions in the direction that would send the bottom bar down through the guides.
- B. While firmly holding the door at the bottom bar, cut the tape and plastic wrap that holds the door in a coil. Direct the bottom bar down into the guides, stopping just past the head stop area.

WARNING!

EXTREME SPRING TENSION CAN CAUSE SERIOUS INJURY OR DEATH. INSTALLATION, REPAIRS AND ADJUSTMENTS MUST BE MADE BY A TRAINED ROLLING SERVICE DOOR SYSTEMS TECHNICIAN USING PROPER TOOLS AND INSTRUCTIONS. DOOR MUST BE FULLY OPEN WHEN MAKING ADJUSTMENTS.

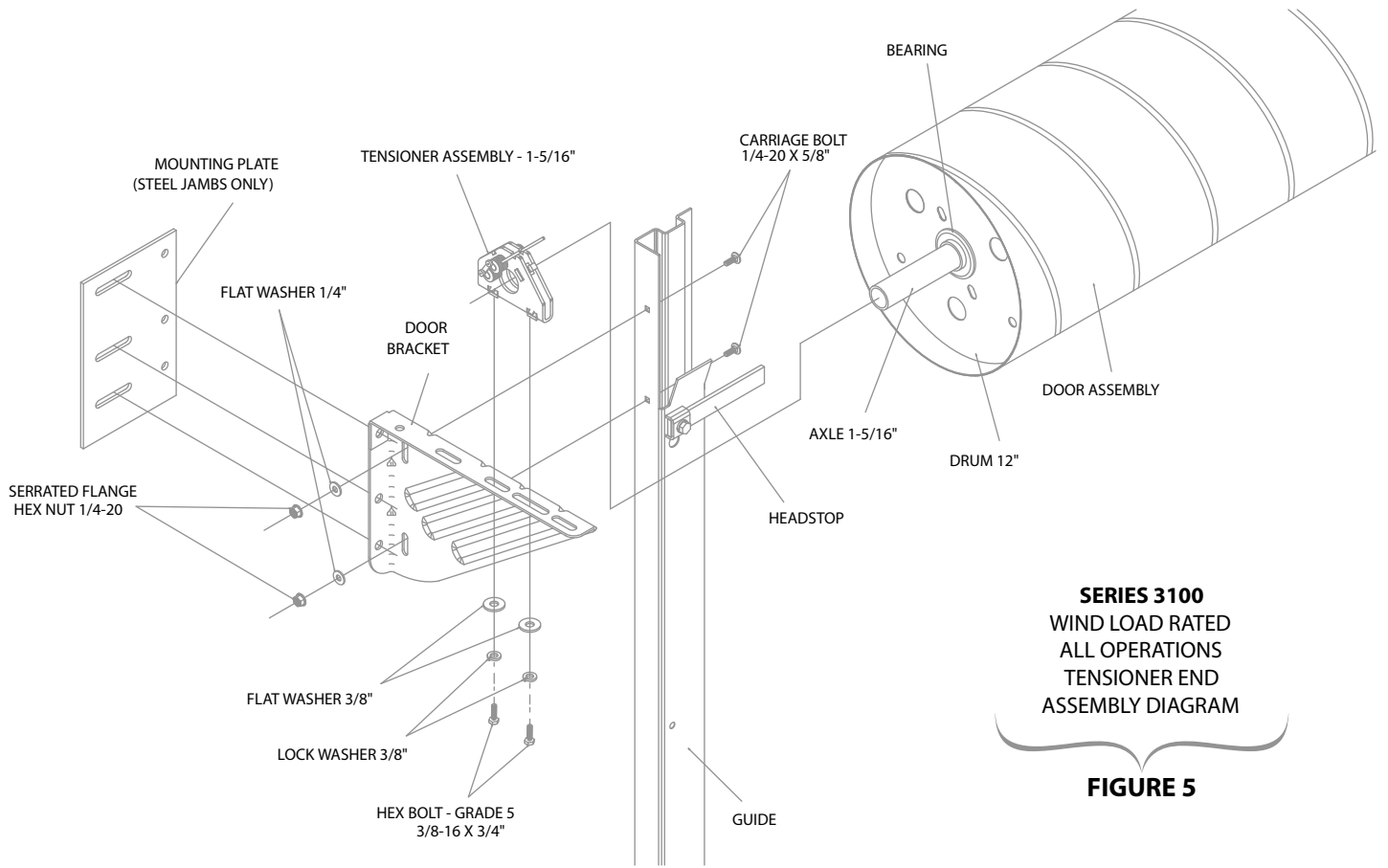

FIGURE 5

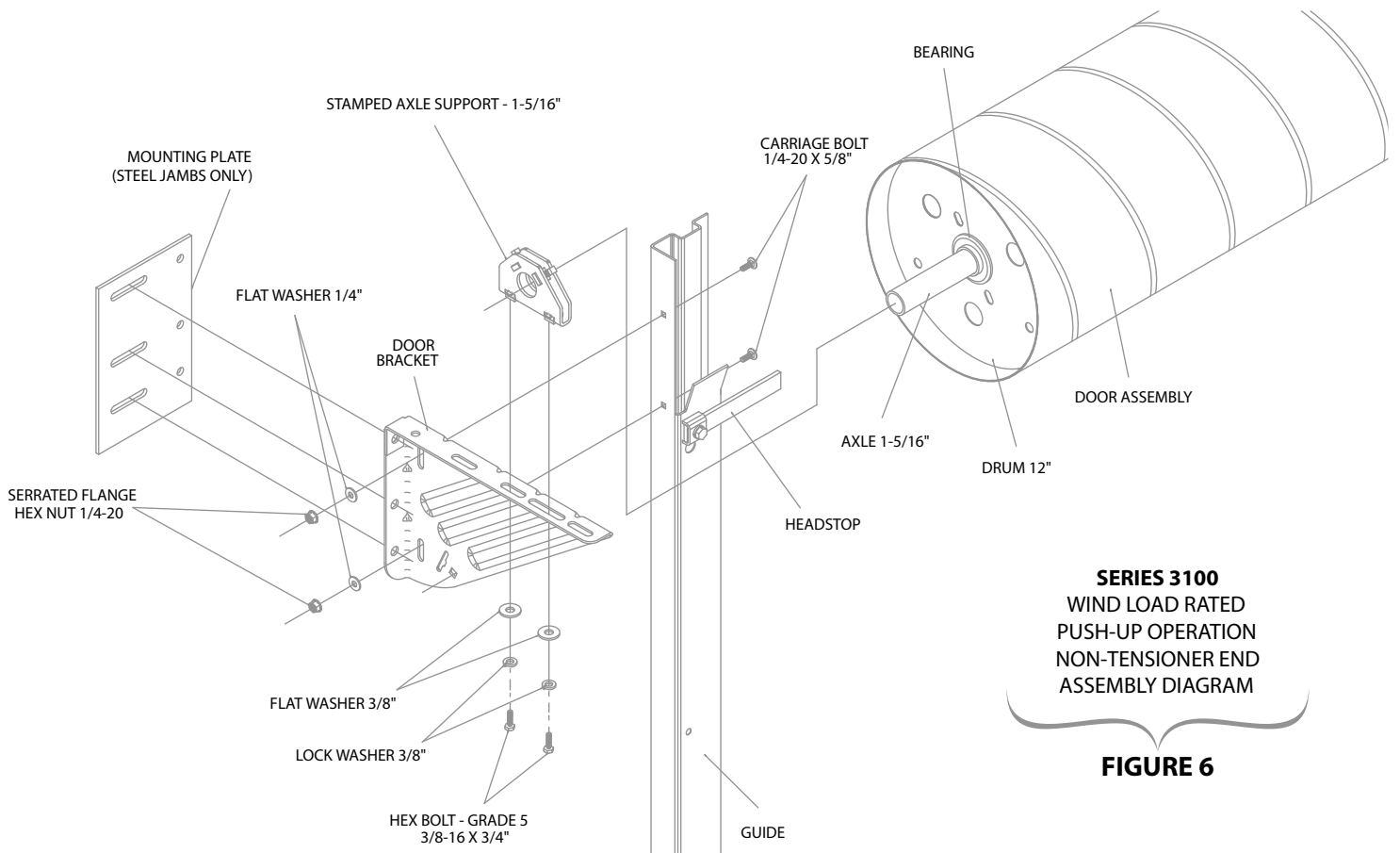
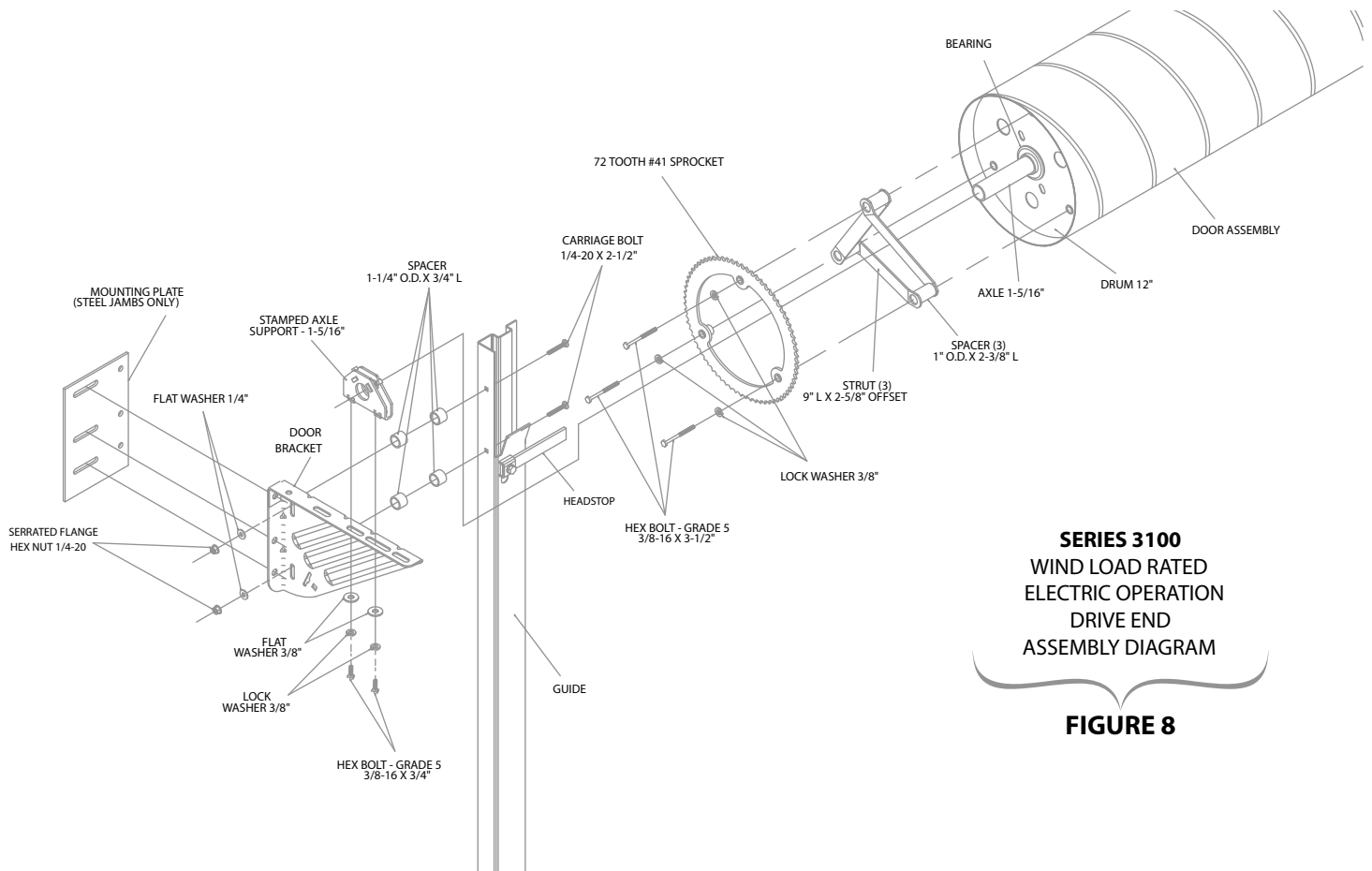
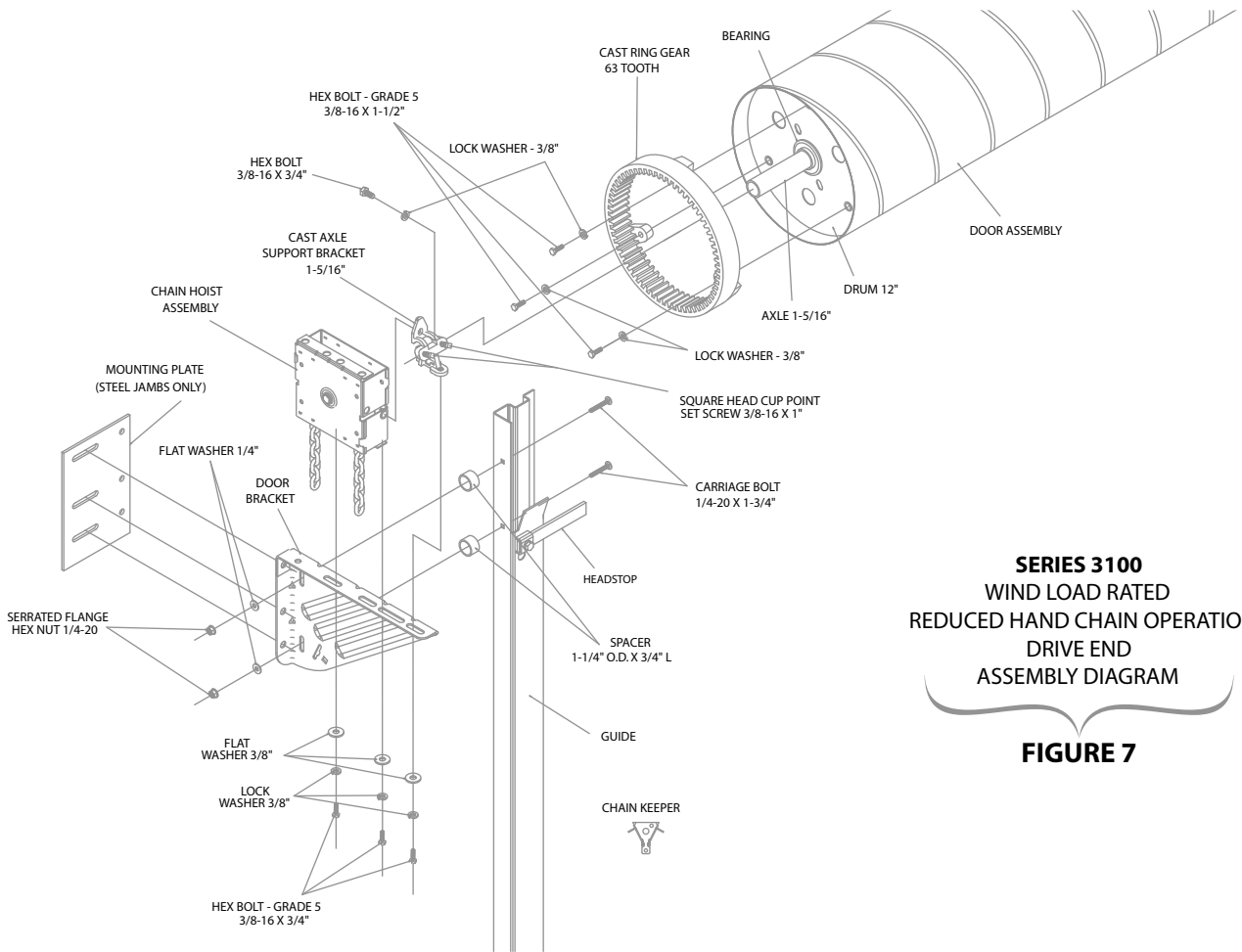

FIGURE 6



STEP 15: HEAD STOPS

- A. Slide head stop from outside of each guide. **See figures 5 through 8.**
- B. Secure each head stop to guide with a 3/8-16 x 1/2" hex bolt and a 3/8" lock washer.

STEP 16: SLIDE LOCK, STEP PLATE AND PULL ROPE

- A. Lower bottom bar and install slide lock and step plate using 2 each 1/4-20 x 1" hex bolts, 5/16-18 hex nuts, 1/4" flat washers and 1/4-20 nylon insert hex nuts. Do this at both ends of bottom bar. **See figure 9.**
- B. Transfer the 1/4-20 x 1/2" carriage bolts and 1/4-20 serrated flange hex nuts that were removed from both ends of the bottom bar to the 2 holes at the center of the bottom bar and angle.
- C. For push-up operation only, install rope in one of the holes at the center of the horizontal leg of the bottom bar angle.

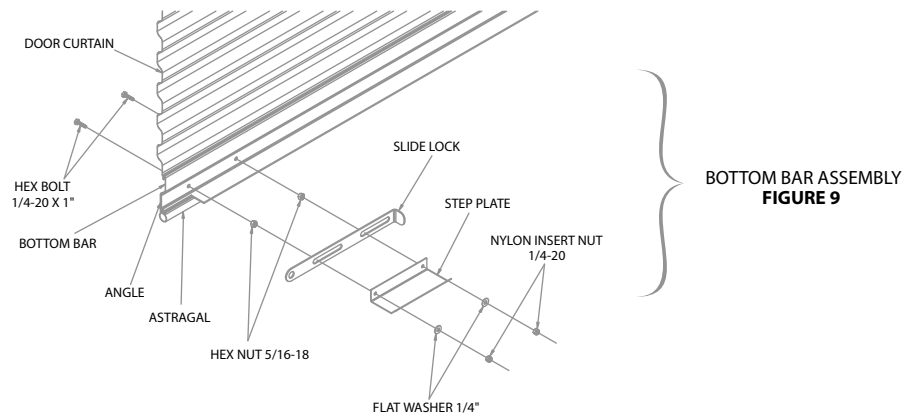

STEP 17: POSITION DOOR

- A. Fully open door.
- B. At both ends of the door, slightly loosen all 3/8-16 x 3/4" hex bolts that go through the door bracket and connect to the tensioner, axle support and chain hoist.
- C. Push door assembly as close as possible toward header and still be able to rotate freely. Each end of door should be equal distance from the header and the curtain must be centered in the opening.
- D. Tighten securely all 3/8-16 x 3/4" hex bolts that were loosened in step 17B.
- E. Tighten all 3/8-16 square head setscrews in tensioner and axle support at both ends of door.

STEP 18: CHECK DOOR OPERATION

- A. Lower and raise the door to test door operation and balance.
- B. If door is easy to close, but hard to open, increase spring tension (See step 19).
- C. If door is hard to close, but easy to open, decrease spring tension (See step 19).



WARNING!

DOOR MUST BE FULLY OPENED WHEN MAKING ADJUSTMENTS.

STEP 19: ADJUST SPRING TENSION (if required)

- A. Loosen all 3/8-16 square head setscrews in tensioner and axle support at both ends of door.
- B. At tensioner end, place pipe wrench around end of axle so that pulling down on the handle will rotate the axle to increase spring tension.
- C. To increase spring tension, pull down on pipe wrench. The tensioner will automatically grip the axle and hold the new tension setting.
- D. To decrease spring tension, momentarily pull down on pipe wrench and then lift the spring roll pin on the tensioner's knurled wheel. Gently let up on pipe wrench, allowing the axle to rotate to reduce the tension. While holding the new tension, release the tensioner's spring roll pin. The tensioner will now grip the axle and hold the new tension setting.
- E. Tighten all 3/8-16 square head setscrews in tensioner and axle support at both ends of door.
- F. Remove pipe wrench and operate door.
- G. Repeat steps 19A through 19F as necessary.

STEP 20: WARNING LABEL

- A. Install warning label at a readable height on the drive side door guide or jamb.